

Technical documentation

WING by VTS



Check us on



WING W100-200
WING E100-200
WING C100-200

WING W100-200
WING E100-200
WING C100-200

1. Table of content

1. INTRODUCTION	4
1.1. PRECAUTIONS, REQUIREMENTS, RECOMMENDATIONS.....	4
1.2. TRANSPORT	4
1.3. INITIAL STEPS TAKEN BEFORE THE INSTALLATION.....	4
2. STRUCTURE, INTENDED USE, PRINCIPLE OF OPERATION	4
2.1. INTENDED USE	4
2.2. PRINCIPLE OF OPERATION	4
2.3. STRUCTURE (WING 100-200).....	5
2.4. OVERALL DIMENSIONS (WING E, W, C 100-200).....	5
3. ASSEMBLY	5
3.1. ASSEMBLY/ DISASSEMBLY OF SIDE COVERS	6
3.2. ASSEMBLY OF DEVICE	6
3.2.1. HORIZONTAL ASSEMBLY WITH USING INSTALATION HANDLES	7
3.2.2. VERTICAL ASSEMBLY WITH USING INSTALATION HANDLES	8
3.3. ASSEMBLY AND INSTALLATION GUIDELINES	8
4. ELEMENTS OF AUTOMATICS.....	11
5. START-UP, OPERATION, MAINTENANCE	11
5.1. START-UP/PUTTING INTO OPERATION	11
5.2. OPERATION AND MAINTENANCE	11
6. SERVICING.....	12
6.1. PROCEDURE IN CASE OF DEFECTS	12
6.2. COMPLAINT PROCEDURE	12
7. INDUSTRIAL SAFETY INSTRUCTION	12
8. TECHNICAL DATA.....	13
8.1. WATER AIR CURTAIN – WING W100-200.....	13
8.2. ELECTRIC AIR CURTAIN – WING E100-200.....	14
8.3. WING C100-200 – COLD AIR CURTAIN	14
9. ELECTRICAL DIAGRAMS	15
9.1. Electrical diagram of WING W100-200-EC - 115V	15
9.2. Electrical diagram of WING C100-200-EC - 115V	16
9.3. Electrical diagram of WING E100-EC – 1~240V	17
9.4. Electrical diagram of WING E150-200-EC -3~240V	18
9.5. Electrical diagram of WING E100-EC- 3~230V and WING E100-200-EC – 3~480V	19

WING W100-200 WING E100-200 WING C100-200

1. INTRODUCTION

1.1. PRECAUTIONS, REQUIREMENTS, RECOMMENDATIONS

Detailed analysis of this documentation, as well as assembly and use of equipment, according to the descriptions contained therein, and following all safety requirements, is the basis for the correct and safe operation of the device. Any other use that contradicts this instruction may cause accidents with serious consequences. Unauthorized personnel should have limited access to the device, while the personnel should be properly trained. The term operational personnel refers to people, who, as the result of completed training, own experience and knowledge of important standards, documentation and provisions, concerning safety and working conditions, have been authorized to carry out necessary work and are able to recognize potential hazards and avoid them. This technical documentation must be delivered together with the device. The documentation contains information concerning all possible configurations of air curtains. Examples of air curtain assembly and installation, as well as activation, use, repair and maintenance. Provided that the device is operated according to the intended use, this documentation contains a sufficient number of instructions, required by the qualified personnel. The documentation should be placed near the device and be readily available to the service team. The manufacturer reserves the right to introduce changes to the instruction, as well as changes to the device that affect its operation, without prior notice. VTS POLSKA Sp. z o.o. shall bear no responsibility for on-going maintenance, inspections, programming of equipment and damage, caused by standstills of equipment related to the waiting for warranty services, all and any damage related to the Client's property, other than the device in question, as well as malfunctions that result from incorrect installation or improper use of the device.

WING air curtains are intended for indoor assembly only. WING air curtains are intended for indoor assembly only.

DO NOT COVER

WARNING: To avoid overheating - do not cover the device!

1.2. TRANSPORT

Prior to the installing and taking the device out of the cardboard box, it is required to check whether the cardboard box has not been damaged in any way and/or the adhesive tape (installed at the company) has not been broken off or cut. It is recommended to check whether the device's casing has not been damaged in transport. Should any of the above situation occur, please contact us through telephone or e-mail: Tel. 0 801 080 073, email: vts.pl@vtsgroup.com, fax: (+48) 12 296 50 75.

The device should be transported by two people. Use appropriate tools, when transporting the device, so as to avoid the damaging of goods and potential hazard to health.

1.3. INITIAL STEPS TAKEN BEFORE THE INSTALLATION

Record the serial number of the device in the warranty card, prior to the commencement of the installation process. It is required to properly fill-in the warranty card, after the completion of the assembly. Prior to the commencing of any installation or maintenance work, it is required to disconnect power supply and protect it against unintentional activation.

Assembly, connection and first start should be performed by qualified personnel, according to the guidelines provided in this manual.

The order of installation steps:

- Mount the device in its intended operation place
- Perform the hydraulic connection, check connections for tightness and vent the system
- Perform the electrical connection
- Make sure the device is correctly connected (according to the diagram)
- In the case of an electrical curtain, vacuum the heaters to avoid the unpleasant smell of burning dust
- Turn the power on and start the device.

2. STRUCTURE, INTENDED USE, PRINCIPLE OF OPERATION

2.1. INTENDED USE

For the convenience of users as well as different types of installations in commercial and industrial facilities we have designed an air curtain in three different options and three sizes:

- a WING W100 curtain 42in wide with a water heater (13.6-58MBH, 1089 CFM)
- a WING E100 curtain 42in wide with electric heaters (6.8/13.6/20.5 MBH, 1089 CFM)
- a WING C100 curtain 42in wide (1107 CFM)
- a WING W150 curtain 61in wide with a water heater (34.1- 109 MBH, 1825 CFM)
- a WING E150 curtain 61in wide with electric heaters (13.6/27.3/40.9 MBH, 1854 CFM)
- a WING C150 curtain 42in wide (1884 CFM)
- a WING W200 curtain 82in wide with a water heater (58- 160 CFM, 2590 CFM)
- a WING E200 curtain 82in wide with electric heaters (20.5/30.7/51 MBH, 2649 CFM)
- a WING C150 curtain 42in wide (2708 CFM)

The above sizes of curtains are available with three options of voltage supply:

- 1x240V
- 3x240V
- 3x480V

! Voltage supply 1x240V is available only for the smallest curtain WING E100.

The use of the WING air curtain enables the leaving of the room door open, regardless of weather conditions, thus providing a protective barrier. The curtain also enables a simultaneous keeping of the required heating comfort inside the room/facility. The modern design of the WING air curtain is a result of its wide range of application. The places in which it is possible to install the device include: malls, office buildings, supermarkets, cinema complexes, as well as shops, store-rooms, manufacturing facilities or warehouse rooms. Please notice that the use of an air curtain not only provides a protective barrier, but also it is an additional heat source in the room. **APPLICATION:** warehouse rooms, warehouses, sports facilities, supermarkets, religious buildings, hotels, clinics, pharmacies, hospitals, office buildings, manufacturing facilities. **PRIMARY ADVANTAGES:** protection of climatic conditions in the room, reduction of heating/cooling costs, universal size, ability to work both in vertical and horizontal position; simple, quick and intuitive assembly.

2.2. PRINCIPLE OF OPERATION

WING W100-200 - heating medium, for example hot heating water, returns heat through a heat exchanger with a wide heat-exchange surface, thus providing high heating output (13.6-160 MBH). A transverse fan (518-2590 CFM) sucks in the air in the room, and pumps it through the heat exchanger, back into the room. The jet of warm air is directed downstream at high velocity, thus providing an air barrier.

WING E100-200 - electric heaters (6.8-51.2 MBH) heat up, as a result of the flowing of electric current, and return the heat to the air; the air is blown off through the fan, which sucks in the air in the room. A jet of warm air is directed downstream at high velocity, thus providing an air barrier.

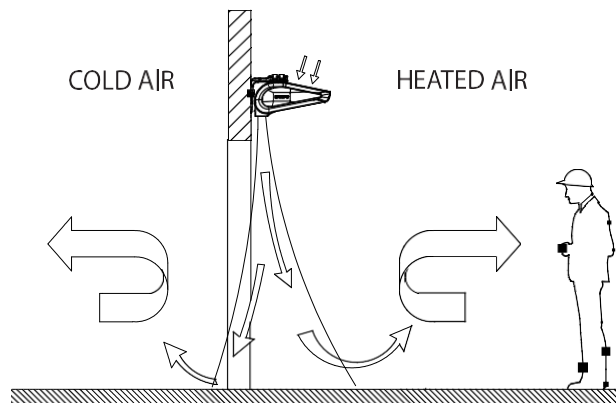

2.3. STRUCTURE (WING 100-200)

WING W100-200 – WATER AIR CURTAIN

1. Heat exchanger
2. Control system
3. Transverse fan
4. Casing
5. Outlet grille
6. Assembly jigs
7. Side cover
8. Side cap

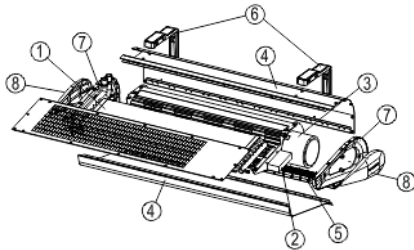

WING E100-200 – ELECTRIC AIR CURTAIN

1. Electric heaters
2. Control system
3. Transverse fan
4. Casing
5. Outlet grille
6. Assembly jigs
7. Side cover
8. Side cap

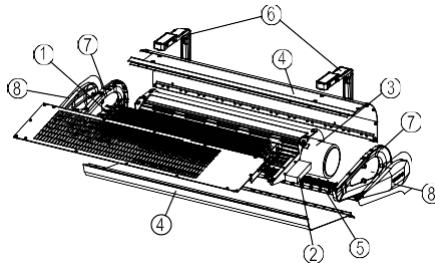

WING C100-200 – COLD AIR CURTAIN

1. Control system
2. Transverse fan
3. Casing
4. Outlet grille
5. Assembly jigs
6. Side cover
7. Side cap

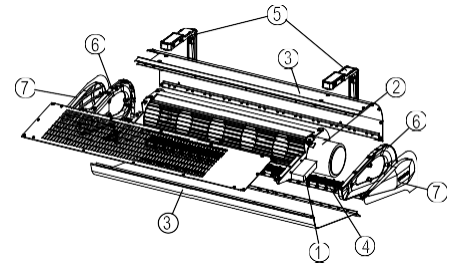

1. HEAT EXCHANGER – WATER HEATER: Maximum parameters of the heating agent for the heat exchanger are: 203°F, 232 psi. The aluminum and copper construction consists of copper pipes of the coil and aluminum lamellae. The connection manifold (3/4" male thread) is situated in the upper part of the housing. An optimally selected water exchanger was adapted to work in three positions: horizontally and vertically, with stub pipes facing upwards and downwards. Appropriate lead of hydraulic connections makes it possible for the curtain to be assembled directly by the wall as close to the door frame as possible. The air curtain with a water heater generates power from 13.6 to 160 MBH.

ELECTRIC HEATER: each electrical curtain consists of 6 electrical heaters of 670W to 2,950W, depending on the size of the curtain. The heaters are connected into two sections of 2 and 4 kW for a 42in curtain, 4 and 8 kW for a 61in curtain, and 6 and 9kW for an 82in curtain. The heating section is connected to form a 1x230V or 3x230V, 3x480V power supply star depend on the chosen device. Thanks to such technical solutions and the application of a wall-mounted controller, the heater of each curtain can work in two heating programs, e.g. for a WING E100 curtain - option 1): heating program 1 - 2kW, heating program 2 - 4kW, option 2): program 1 - 4kW, program 2 - 6kW, and analogously for the remaining curtain sizes. Change of program is displayed on the diagram and consists in a cable switch in controller HMI. The heating program is independent from the fan speed setting.

Electric heater are protected with 4 thermostats, 2 for each section: one with automatic reset and second with manual reset. The thermostat button for manual reset is available to push from the top of the curtain via the top cover grid on the motor side.

2. CONTROL SYSTEM: it is equipped with an outlet on the connection clamp block X1 for WING W100-200 and on the X2 block for WING E100-200 for connecting an on-wall controller as well as a valve actuator for WING W100-200. WING air curtains can be additionally equipped with a wall-mounted DX controller. The DX controller has a three-position heating switch. In the case of a water curtain, to guarantee the proper functioning of the water valve, the heating switch must be set to position II (central) - otherwise the valve will not open. The system of WING E100-200 is equipped with a safety device in the form of a fuse in the 115 V AC circuit.

3. HORIZONTAL FAN: the maximum temperature of operation is 203°F; the rated voltage is 115 V/60Hz. The motor protection level is IP44. The horizontal fan applied in the device with an advanced profile of blades and impeller geometry made of plastic makes it possible to obtain air capacities up to 2648 CFM. The control of the electric motor as well as thermal protections of the winding has been coupled with the control system which resulted in increasing safety of operation. Due to optimum power of the motor the WING curtain is energy saving and durable.

5. INSTALLATION HANDLES: WING is characterized by simple, quick and aesthetic assembly that can be performed on a wall in both horizontal and vertical position. There are from 2 to 3 installation handles attached (as an option) to the curtain (depending on the option (length)). Connections of electric wires and water channels have been especially designed not to interfere with the general aesthetic values of the device. The name WING includes devices that are 42, 61 and 82in long that, if necessary, can be additionally joined both horizontally and vertically to achieve different air supply options: from the left to the right and the opposite. The reach of the air stream is up to 13 ft.

IMPORTANT! Possibility of the vertical assembly applies only to the cold curtains and with water heater. Curtains with electric heaters may only be installed in a horizontal position.

2.4. OVERALL DIMENSIONS (WING E, W, C 100-200)

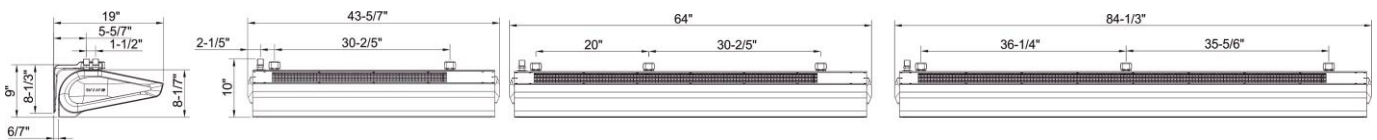

3. ASSEMBLY

IMPORTANT!

- The place of assembly should be carefully selected, taking into account the occurring of potential loads or vibrations.
- Prior to all installation or maintenance work, disconnect power supply and secure it against unintentional reactivation.
- It is recommended to use filters in the hydraulic system. It is recommended to clean/rinse the system, draining a few liters of water, prior to the connecting of hydraulic conduits (the supply conduits, in particular).

IMPORTANT!

The air is blown out of the curtain at high velocity, along the surface of the opening, thus creating a protective barrier. Air curtains should cover the entire width of the door opening, in order to obtain the maximum performance of the curtain.

IT IS RECOMMENDED TO TAKE INTO ACCOUNT THE FOLLOWING PARAMETERS, WHEN ASSEMBLING THE CURTAIN:

The width of the door frame should be less or equal to the width of the supplied air stream.

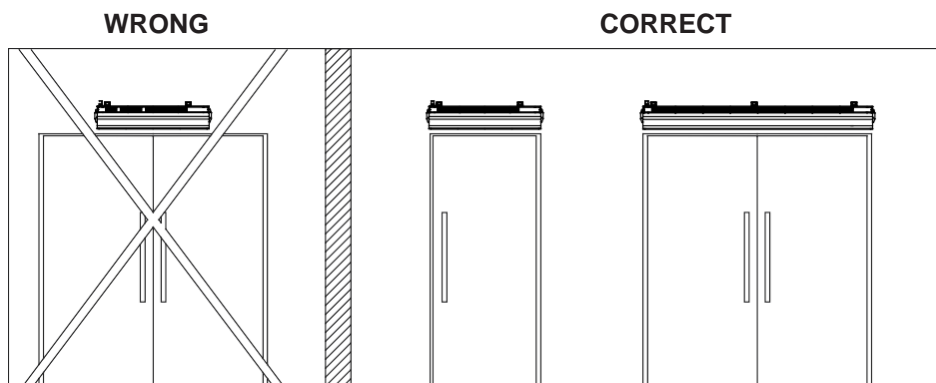

WING W100-200 WING E100-200 WING C100-200

The range of the air jet - assembly height

- Horizontal installation

fan speed	III	II	I
height of assembly [ft]	H3	H2	H1
WING W100, W150, W200	12	9-1/2	7-1/2
WING E100, E150, E200	12	9-1/2	7-1/2
WING C100, C150, C200	13	9-1/2	7-1/2

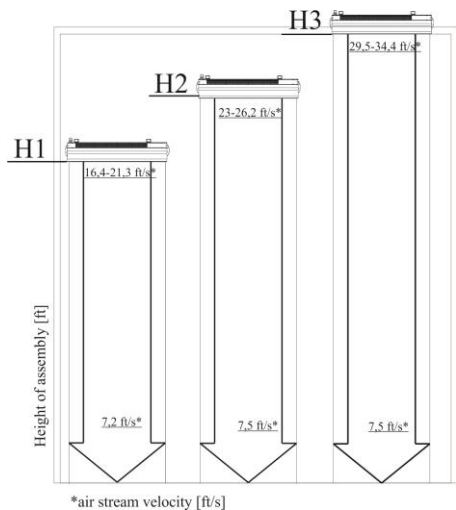

- Vertical installation

fan speed	III	II	I
width of the door [ft]	H3	H2	H1
WING W100, W150, W200	12	9-1/2	7-1/2
WING C100, C150, C200	13	9-1/2	7-1/2

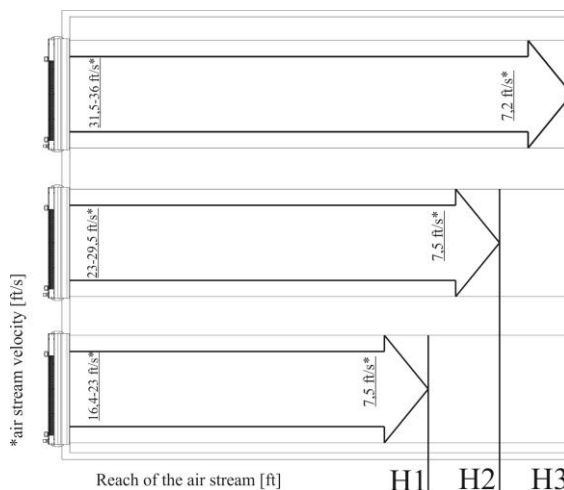

IMPORTANT! The heating output should be adjusted to the temperature inside the room, as well as the strength and direction of the wind outside. The primary criterion for the regulation of the heating power is the temperature inside the room, near the door. Should a room thermostat be used, WING activates the heating mode, depending on the temperature settings.

IMPORTANT! Please consider additional factors that affect device operation.

Factors that have a negative effect on curtain operation	Factors that have a positive effect on curtain operation
doors or windows that are constantly open in the room, thus creating a draft	presence of awning, roofs etc. on the outer side of the door
constant and open access to staircases, available through the room, the chimney draft effect	use of revolving doors

3.1. ASSEMBLY/ DISASSEMBLY OF SIDE COVERS

In order to remove the outlet grid you should carefully level the grid catches located with the use of a screwdriver and pull it away. Having installed the device and connected it to the electric supply put the grid back by clicking it on the catches. It is also possible to access to the terminal strip by opening the cover on the top of curtain. In order to do it, should unscrew 6 screws.

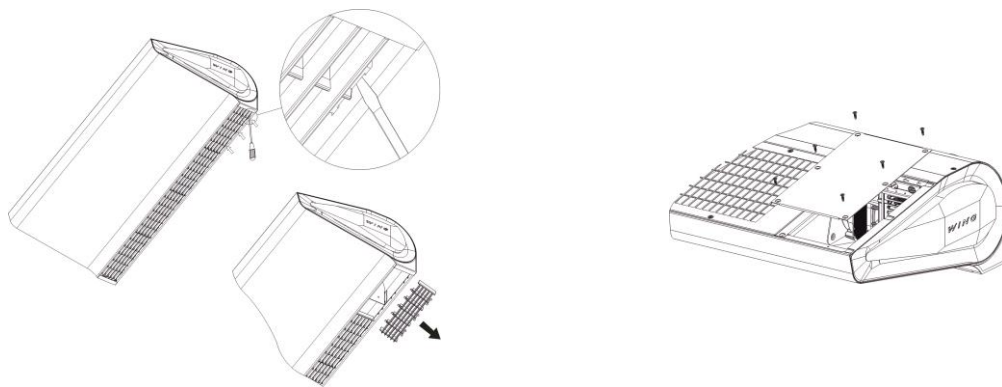

3.2. ASSEMBLY OF DEVICE

For directly installation use the threaded sleeves (M8) in the top of the device.

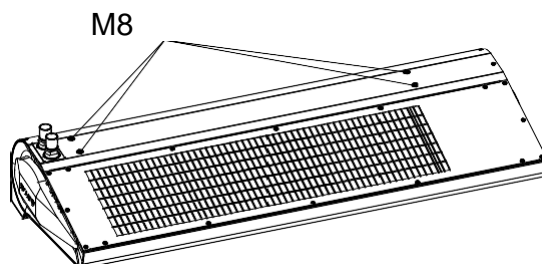

IMPORTANT! The minimum distance between the unit and the ceiling should be 4 in.

3.2.1. HORIZONTAL ASSEMBLY WITH USING INSTALATION HANDLES.

It is possible to assemble WING do the wall horizontally in two options:

OPTION I: Assembling handles with their arms faced downwards. In this option you should first screw the installation handles to the wall (1) with intervals W1 for a 42in curtain (there are 2 installation handles) and W1, W2 for 61in and 82in curtain (there are 3 installation handles) so that the handles' arms are levelled. Then lift the curtain and assembly with using screws (2) 1/4-UNC x 3/4 and plain washers (3). Tighten the screws (2) and close the handle's covers (4).

ATTENTION! The minimum distance between the unit and the ceiling should be 1 ft.

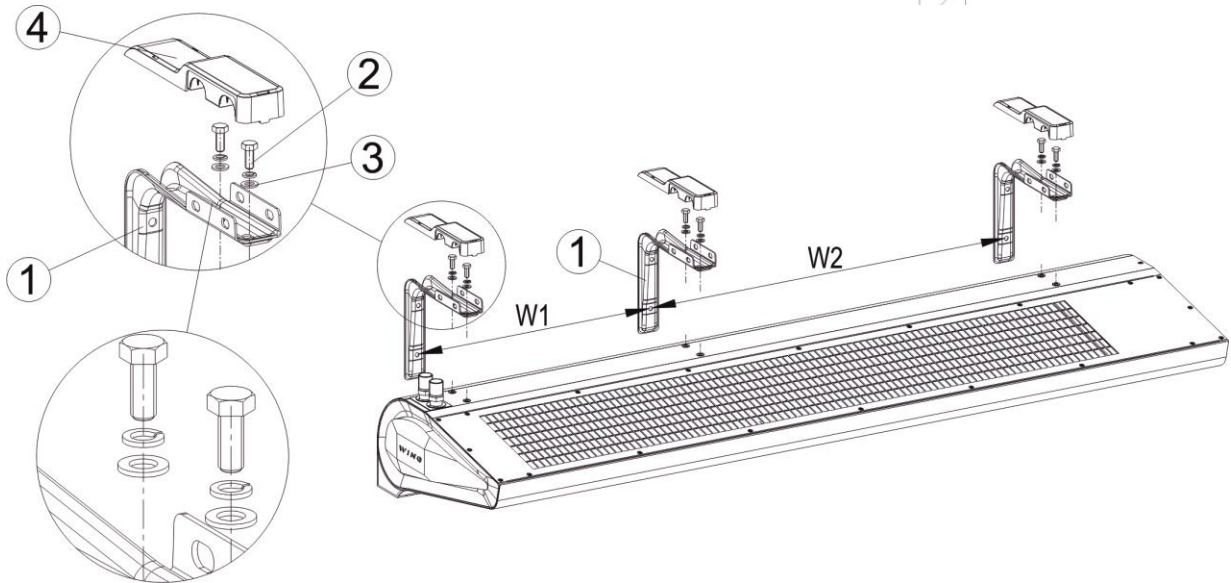
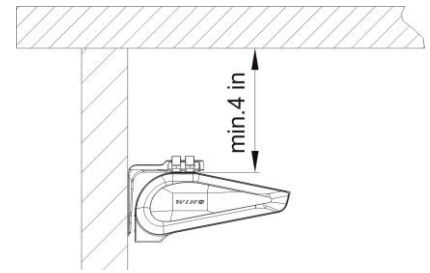

	W1 [in]	W2 [in]
WING W, E, C100	30	-
WING W, E, C150	20	30
WING W, E, C200	36	35

OPTION II: Assembling handles with their arms faced upwards.

Assembly consists in screwing brackets to the curtain (1). To mount the brackets to the curtain, with the housing upside down, punch holes (5) from the outside in the shields (4) using a hammer and a screw. Click the shields on the brackets (1). Mount the brackets on the curtain using 1/4-UNC x 3/4 screws (2) and washers (3). This assembly option allows for mounting brackets to the curtain first, and then screwing the entire housing to the wall.

ATTENTION! The minimum distance between the unit and the ceiling should be 4 in.

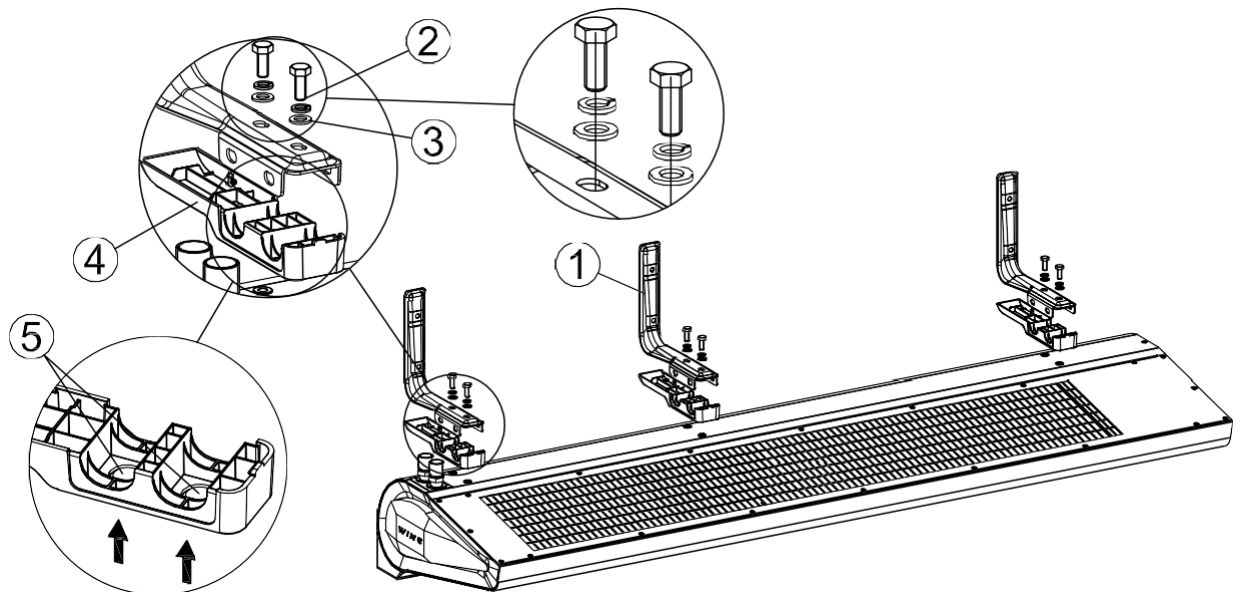

WING W100-200
 WING E100-200
 WING C100-200

3.2.2. VERTICAL ASSEMBLY WITH USING INSTALATION HANDLES.

It is possible to assemble WING to a wall vertically on both sides of the gate (with the motor on the bottom or on the top). For this option it is not important if you screw the handles down to the unit first and then screw the whole down to the wall or first attach the handles to the wall and then screw the curtain down to the handles.

To perform vertical assembly, use 1/4-UNC x 2 3/4 (outside the scope of VTS delivery) screws. Screw 2 or 3 brackets using the screws, passing through flat washers (3), to the threaded sleeves mounted in the upper part of the housing.

IMPORTANT: In case of vertical assembly the minimal distance between the device and the floor (4 in) for access to the water coil blowdown connection and the cable terminal should be provide.

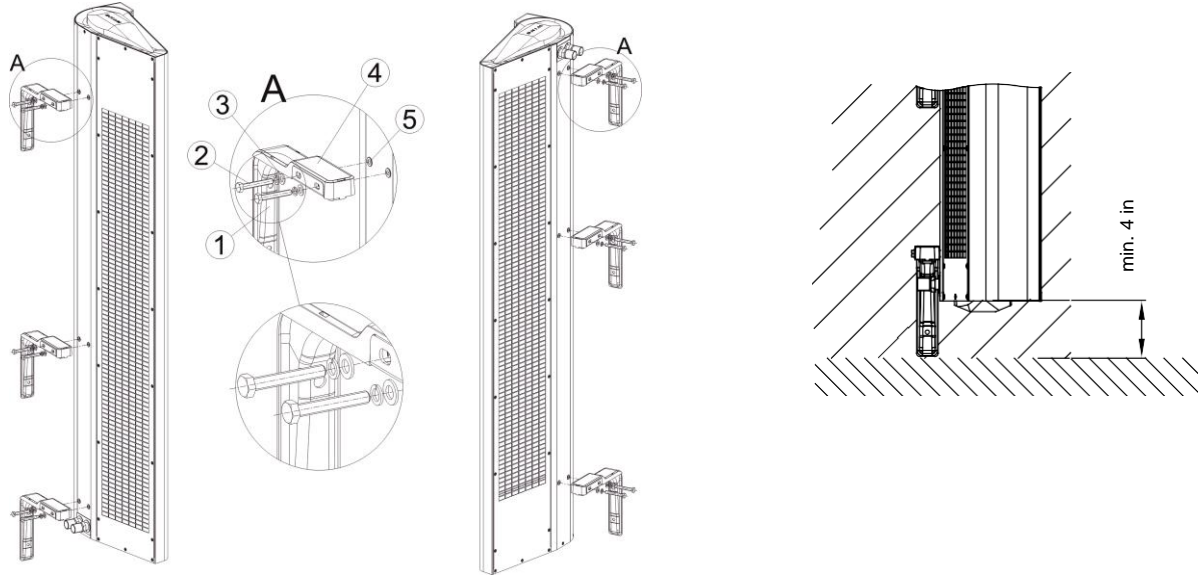

IMPORTANT! The device is intended for the operation in dry rooms, exclusively. Thus, pay particular attention to the condensation of water vapor on engine elements, since it is not fitted for operating in humid environment.

IMPORTANT! The WING air curtains are not intended for the installation:

- Outdoors;
- In humid rooms;
- In rooms categorized as explosive environments;
- In rooms with very high levels of dustiness;
- In rooms with aggressive atmosphere (due to the presence of copper and aluminum structural elements in the heat exchanger and electric heaters).

IMPORTANT! The WING EH air curtains are not intended for the installation on suspended ceilings.

3.3. ASSEMBLY AND INSTALLATION GUIDELINES

CONNECTING OF HEATING MEDIUM

Protect the heat exchanger terminal against the impact of the torque moment 1, when installing a pipeline transporting a heating medium. The weight of installed pipelines should not impose a load on the heater's terminals.

IMPORTANT! Pay particular attention to the leak-tightness of connections, when filing the hydraulic system. Make sure that the water flowing from a leaky connection does not leak to the electric engine (at the vertical assembly)

IMPORTANT! It is recommended to use filters in the hydraulic system. It is recommended to clean/rinse the system, draining a few liters of water, prior to the connecting of hydraulic conduits (the supply conduits, in particular).

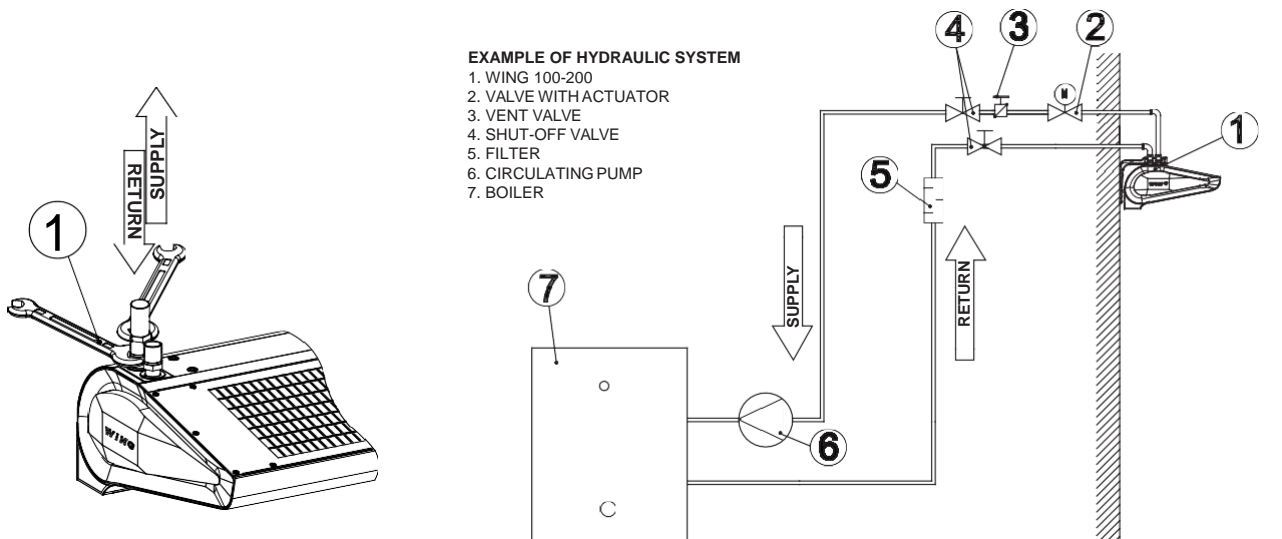

VENTING OF DEVICE/DRAINING OF HEATING MEDIUM

To perform horizontal and vertical assembly, the exchanger on the right-hand side of the door vents automatically. In the case of lateral assembly with the stub pipes facing downwards, to vent the exchanger, remove the side cover. Unscrew the screws (1) around the cover and remove the cover. A valve with a hose is situated below the cover.

VENTING OF DEVICE/DRAINING OF HEATING MEDIUM

Venting of the curtain water coil followed by loosening the union connection on the outlet connection. In case of the vertical assembly with the coils connection on the bottom side, the access to the vent valve is by removing the side cover. To do it one should remove the screws (1) around the cover and remove the cover. There is a valve (2) with a hose.

WORKING POSITION			
A	horizontal (downward air feed)	drain	automatic venting
B	vertical (air feed from left to right)	drain	automatic venting
C	vertical (air feed from right to left)	venting	drain

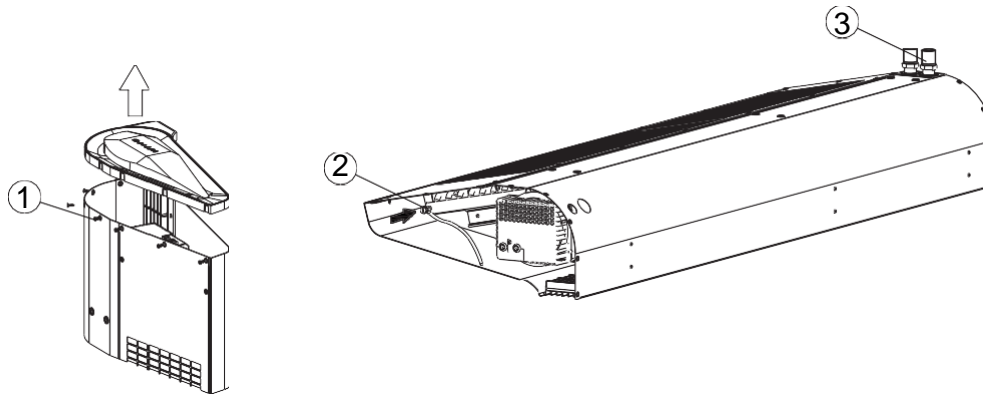

IMPORTANT! While venting the exchanger you should pay special attention to securing the device against accidental penetration of water into electrical elements.

IMPORTANT! Remember to vent the heater, if it has been activated after a prior draining of the heating medium.

IMPORTANT! Pay particular attention to the leak-tightness of connections, when filling the hydraulic system. Make sure that the water flowing from a leaky connection does not leak to the electric engine (at the vertical assembly).

CONNECTING OF POWER SUPPLY

IMPORTANT! The system must be equipped with protective equipment that guarantees the disconnecting of the device on all poles of the power source.

Connection to the electric system must be performed by a duly authorized and qualified person. Wire passes are located on the back side of the curtain: (1) – control wire packing, (2) – power wire packing. The access to the terminal strip is obtained by means of removing the outlet grid (3) from the motor's side. It is required to mount the cable strain relief (5), to protect the cable (4) against pulling.

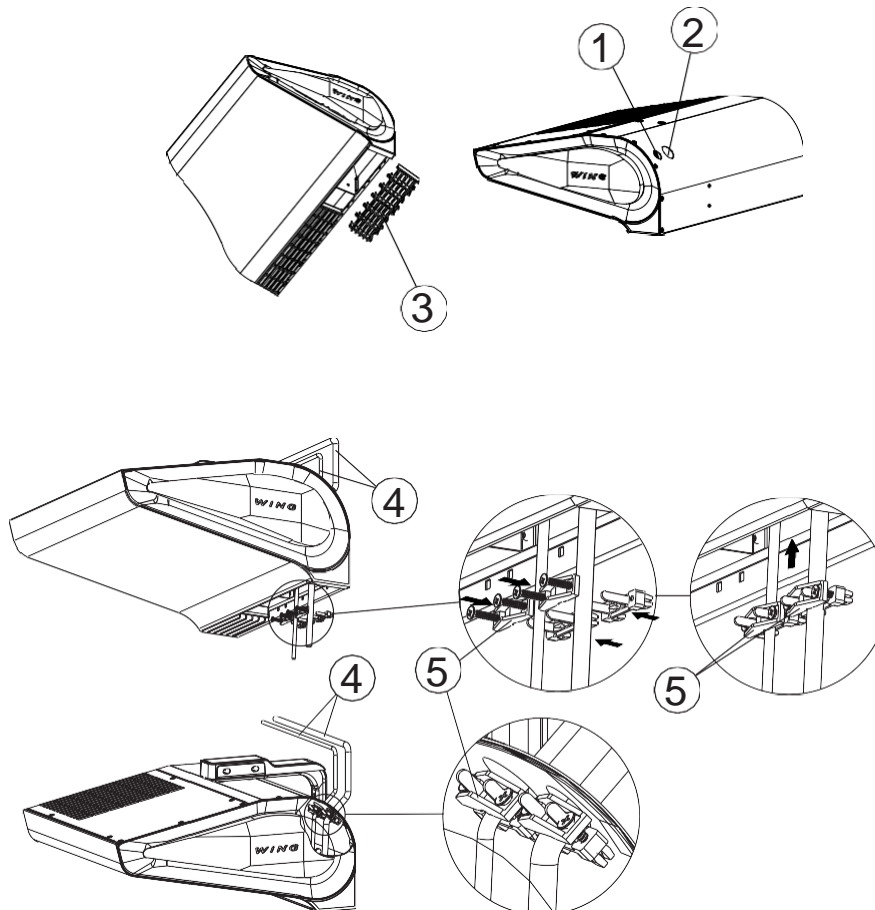

WING W100-200 WING E100-200 WING C100-200

Recommended safety devices and wires

Device	WING E100-200		
	W100	W150	W200
Supply voltage 1~240V			
MOP	55		
MCA	33.1A		
FLA	26.5A		
Power wire cross-section	8 AWG		
Supply voltage 3~240V			
MOP	35	65	85
MCA	19.5A	37.8A	47.5A
FLA	15.6A	30.2A	38A
Power wire cross-section	14 AWG	8 AWG	8 AWG
Supply voltage 3~480V			
MOP	15	35	45
MCA	10.5A	19.8A	25A
FLA	8.4A	15.8A	20A
Power wire cross-section	14 AWG		

Device	WING W100-200 WING C100-200		
	W100	W150	W200
Fan supply voltage 1~115V			
MOP	15	15	15
MCA	10.5A	19.8A	25A
FLA	8.4A	15.8A	20A
Power wire cross-section	14 AWG		

IMPORTANT! The specification of cables and protections refers to unbounded arrangement of. One should always abide by the local laws and recommendations concerning device connection.

WING is equipped with a terminal strip adjusted to an appropriate thickness of wires.

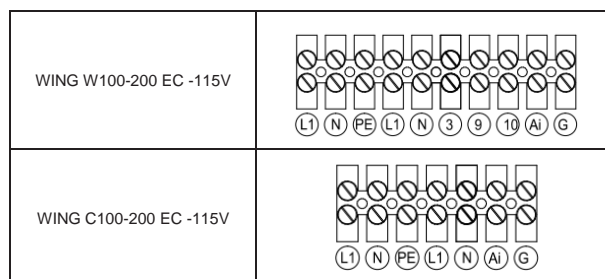
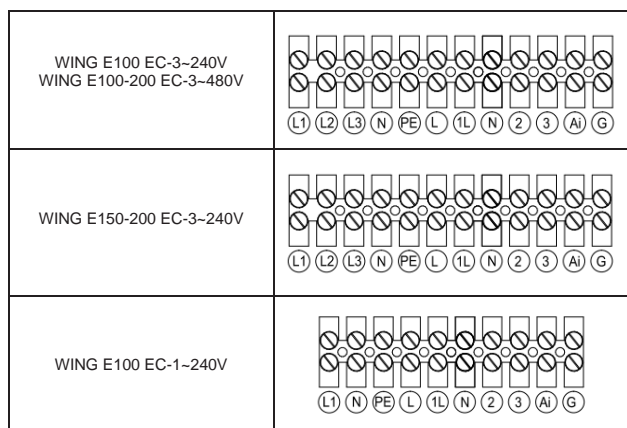

EN

IMPORTANT!

- It is recommended to connect wires to the terminal strip with previously clamped appropriate clip ends.
- Make sure that the space around the place where the air is sucked in by the curtains, as well as around the exhaust grid, is free of any structural elements of the building, which might hamper the flow of air (e.g. suspended ceilings, covering development, ventilating ducts etc.).

4. ELEMENTS OF AUTOMATICS.

Electrical connections can be carried out only by qualified electricians, according to the binding regulations of:

- industrial safety;
- assembly instructions;
- technical documentation for each individual element of automatics.

IMPORTANT! Study the original documentation delivered together with the elements of automatics, prior to the commencing of assembly and connecting of the system.

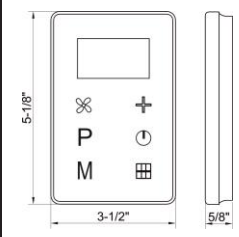
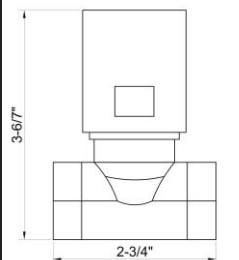
MODEL	DIAGRAM	TECHNICAL DATA	COMMENTS
WALL-MOUNTED CONTROL PANEL		HMI-WING EC <ul style="list-style-type: none"> • Device operation: Capacitive touch buttons • Power supply: 230 V AC • Temperature measurement: 14 °F ... 210 °F ; NTC10K • Outputs: <ul style="list-style-type: none"> - 1 analog output 0-10V (8 bit, I_{max} = 20mA) - 2 relays outputs (250 VAC, AC1 500 VA dla 230 VAC) • Inputs: 1 digital input type "dry contact", I_{max} = 20 mA • Communication: Modbus RTU • Parameters of working environment: temperature: 32 - 140 °F, humidity: 10 - 90%, without condensation 	<ul style="list-style-type: none"> • used for control all types of WING EC curtains • touch control panel • the main on / off switch (ON / OFF) • three-stage adjustable fan speed of the EC motor • built-in thermostat with possibility weekly programming • continuous mode • function of heating and ventilation • door sensor operation • two-stage adjustable of heating power • RS 485 with Modbus RTU • Suggested cross sections of electrical cables:: <ul style="list-style-type: none"> - L, N : 0.08x0.04 in² - H1, H2 : 0.08x0.04 in² - AO, GND : 0.08x0.02 in² LIYCY - Door sensor : 0.08x0.02 in² LIYCY - RS 485 : 0.12x0.03 in² LIYCY
TWO-WAY VALVE WITH ACTUATOR		TWO-WAY VALVE <ul style="list-style-type: none"> • Terminal diameter: 3/4" • Mode of operation: two-way ON/OFF • Maximum differential pressure: 13psi • Pressure class: PN 16 • Kvs flow ratio: 2.65 CFM • Maximum temperature of heating medium: 221 °F • Parameters of working environment: from 32 to 140 °F VALVE ACTUATOR <ul style="list-style-type: none"> • Power consumption: 7 VA • Supply voltage: 230VAC +/-10% • Closing/opening time: 4-5/9-11 s • Position without power: closed • Level of protection: IP54 • Parameters of working environment: from 89 to 284 °F 	<ul style="list-style-type: none"> • It is recommended to install a two-way valve on the return pipeline. • The drawings with the elements of automatics contain only visualizations of sample products. • It is recommended to connect the supply, using a conductor of the min. size 0.08x0.03 in². • The drawings with the elements of automatics contain only visualizations of sample products.

IMPORTANT! If required, the conductors that belong to additional elements of control automatics (thermostat, door switch, wall-mounted controller) should be installed in separate cable channels, out-of-parallel to the supply conductors.

5. START-UP, OPERATION, MAINTENANCE

5.1. START-UP/PUTTING INTO OPERATION

- Prior to the commencing of any installation or maintenance work, disconnect power supply and secure it against unintentional reactivation.
- It is recommended to use filters in the hydraulic system. It is recommended to clean/rinse the system, draining a few liters of water, prior to the connecting of hydraulic conduits (the supply conduits, in particular).
- It is advised to use vent valves in the highest point of the system.
- It is recommended to install shut-off valves directly after the device, should the disassembly of the device be necessary.
- All protective equipment is to be installed before the pressure increases, according to maximum the permissible pressure rating of 232 psi.
- Hydraulic connection should be free of any stresses and loads.
- Check the correctness of hydraulic connections (leak-tightness of the vent, collecting pipes, correctness of fittings installation), prior to the initial start-up of the device.
- It is recommended to check the correctness of electrical connections (of automatics, power supply), prior to the initial start-up of the device. It is advised to use an additional, external residual-current protection.

IMPORTANT! All connections should be carried out, according to this technical documentation and the documentation delivered with automation equipment.

5.2. OPERATION AND MAINTENANCE

- It is advised to carefully analyze all the operational and assembly guidelines listed in chapter 3 and 4.
- The casing of the device does not require maintenance.
- The heat exchanger should be cleaned on a regular basis from dust and fat deposit. It is especially recommended to clean the exchanger before the heating season with the use of compressed air from the air intake side (after removing the inlet grid). You should pay special attention to the exchanger's lamellae which are very delicate.
- Should the lamellas be deformed (bent), straighten them with a special tool.
- The fan's motor does not require any exploitation service, the only service activities that may be necessary concern cleaning the air intakes from dust and fat deposit.
- Disconnect phase voltage, if the device is shut down for longer periods of time.
- The heat exchanger does not have any anti-freezing protections.
- It is recommended to provide a periodical purging of the heat exchanger, preferably using compressed air.
- Should the temperature in the room drop below 32 °F, with a simultaneous drop of the heating medium temperature, there is a risk that the heat exchanger might freeze (crack).
- The level of air pollutants should meet the criteria allowable concentrations of pollutants in indoor air, for non-industrial areas, the level of dust concentration up to 1.87x10⁻⁵ lbs/ft³.
- It is forbidden to use device for the duration of the construction works except for the start-up of the system.
- The equipment must be operated in rooms used throughout the year, and in which there is no condensation (large fluctuations in temperature, especially below the dew point of the moisture content). The device should not be exposed to direct UV rays.
- The device should be operated at the supply water temperature up to 194 °F with working fan.

6. SERVICING

6.1. PROCEDURE IN CASE OF DEFECTS

WING W100-200/EHN		
Symptoms	What to check	Description
Leakage in the WING W100-200 heat exchanger	<ul style="list-style-type: none"> Fitting of the heat exchanger terminals, using two keys acting in two opposite directions (apply the keys on each terminal), which protects against the possibility of internal breaking of the collecting pipes. Relation between the leaking and a potential mechanical damage to the exchanger. Leaking of vent valve elements or drain plug. Parameters of the heating medium (pressure and temperature) should not exceed the permissible values. Correctness of the draining of the exchanger. type of agent (it cannot be any aggressive substance Al or Cu active), Circumstances in which leaking occurred (e.g. during the trial/initial start-up of the system; after having drained the heating medium, followed by the filling of the system) and the external ambient temperature at the moment of the defect taking place (freezing hazard to the exchanger). Potentially aggressive atmosphere (air) in the place of work (e.g. high concentration of ammonia in the sewage-treatment plant). 	<ul style="list-style-type: none"> Pay particular attention to the possibility of the freezing of the heat exchanger in the winter. 99% of leaks occur during start-up/pressure checks. The rectifying of the defect consists in the pulling back of the vent/drain valve.
The fan of the device works too loudly WING W100-200, EHN	<ul style="list-style-type: none"> Installation of the device, according to the guidelines in the Operation and Maintenance Documentation (among others, the distance from the ceiling). 	<ul style="list-style-type: none"> Minimum distance: 4 in from the ceiling
	<ul style="list-style-type: none"> Correctness of the horizontal alignment of the device. Correctness of electrical connections and qualifications of Parameters of the supply current (among others: voltage, frequency). Incorrect covering of the curtain in the suspended ceiling. Noise in lower speeds (damaged winding). Noise present only in the higher speeds – blocking of the air outlet. Type of other equipment working in the facility (e.g. exhaust fans) – increasing noise may be a result of several pieces of equipment working simultaneously. 	<ul style="list-style-type: none"> Louder operation of WING devices may be a result of inappropriate place of assembly: e.g. choking the fan or the acoustic specifics of a room.
The fan in the device is not operational WING W100-200	<ul style="list-style-type: none"> Correctness and quality of electrical connections and qualifications of the fitter. Parameters of the supply current (among others: voltage, frequency) on the terminal block of the fan's engine. Operational correctness of other pieces of equipment present in the facility. Correct fitting of the conduits on the engine side – information available from VTS Service Department. Voltage on the PE conductor (if present, it may indicate a breakdown). 	<ul style="list-style-type: none"> The electrical connection of the device must be carried out, according to the diagrams found in the Operation and Maintenance Documentation.
Damaged casing of the device WING W100-200	<ul style="list-style-type: none"> Circumstances in which the defect occurred: remarks on the bill of lading, inventory issue, condition of cardboard). 	<ul style="list-style-type: none"> Should the casing be defective, it is required to present photos of the cardboard and device, as well as photos that confirm the compliance between the serial number on the device and cardboard. If the damage was done in transport, it is necessary to prepare a proper statement by the driver/forwarder that delivered the goods.
Actuator does not open the valve	<ul style="list-style-type: none"> Correctness of electrical connections and qualifications of the fitter. Operational correctness of the thermostat (the characteristic "ticking" when switching the device). Parameters of the supply current (among others: voltage). 	<ul style="list-style-type: none"> The most important step is to check whether the actuator has reacted to the electrical impulse within 11 s. When actuator damage is claimed, a complaint must be submitted for the damaged element, and the actuator must be uninstalled from the valve to open the valve mechanically (permanently).



It is forbidden to place, dispose of and store worn-out electric and electronic equipment, together with other waste. Dangerous compound contained in electronic and electric equipment have a very adverse impact on plants, micro-organisms, and, most importantly, on humans, as they damage our central and peripheral nervous system, as well as circulatory and internal system. Additionally, they cause serious allergic reactions. Worn-out equipment is to be delivered to a local collection point for used electric equipment, which carries out a selective collection of waste.

REMEMBER!

The user of equipment intended for households, and which has been worn out, is obliged to transfer such equipment to a collecting unit that collects worn-out electric and electronic equipment. The selective collecting and further processing of waste from households contributes to the protection of environment, reduces the penetration of hazardous substances into the atmosphere and surface waters.

6.2. COMPLAINT PROCEDURE

In order to report a problem with the device or elements of automation, please fill in and send the appropriate form (p.74), using one of the three available ways:

- E-mail: vts.pl@vtsgroup.com
- Fax: (+48) 12 296 50 75
- Website: www.vtsgroup.pl/PRODUKT/VTS_Service/formularz_zgloszeniowy

Our service department will contact you immediately.

In the case of damage in transport, send a complaint notification, including the delivery documentation (bill of lading, inventory issue) and photographs showing the defects.

Should you have any questions, please contact us, using this telephone number: 0 801 080 073

IMPORTANT! The complaint procedure shall be initiated when the Service Department has received a correctly filled complaint notification, a copy of the purchase invoice and the Warranty Card, filled by the company that carried out the installation.

7. INDUSTRIAL SAFETY INSTRUCTION

Special instructions concerning safety

IMPORTANT!

- Prior to the commencing of any work related to the device, it is required to disconnect the system, secure it properly and wait, until the fan stops revolving.
- Use stable working platforms and hoists.
- Depending on the temperature of the heating medium, pipes, elements of casing and surfaces of the heat exchanger can be very hot, even after the fan has stopped revolving.
- Sharp edges may be present! Wear gloves, protective shoes and clothing, when transporting the device.
- Strictly observe safety guidelines and industrial safety regulations.
- Loads can be placed only in the previously selected areas on the transporting unit. Protect the edges of the device, when lifting it, using a set of machines. Remember to distribute weight evenly.
- The equipment must be protected against moisture and dirt, and kept in rooms protected against the impact of weather conditions.
- Utilization of waste: make sure that operating and auxiliary materials, including packaging material and spare parts, are disposed of in a safe, environment friendly manner, according to the binding, local statutory regulations.

8. TECHNICAL DATA

8.1. WATER AIR CURTAIN – WING W100-200

T_w – temperature of water at the inlet to the device
 T_p – temperature of water at the outlet from the device
 T_{p1} – temperature of air at the inlet to the device
 T_{p2} – temperature of air at the outlet from the device
 P_g – heating output of the device
 Q_w – water flow
 Δp – pressure drop in the heat exchanger

Parameters	WING W100															
	194/158				176/140				158/122				140/104			
T_w [°F]	41	50	59	68	41	50	59	68	41	50	59	68	41	50	59	68
	<i>III/1088[CFM]/59dB(A)*</i>															
P_g [MBH]	60	55	50	46	50	45	40	35	39	34	29	23	27	17	14	12
T_{p1} [°F]	89	95	101	107	81	87	92	98	73	78	83	88	63	64	71	78
Q_w [CFM]	0.47	0.41	0.41	0.35	0.41	0.35	0.29	0.29	0.29	0.29	0.24	0.18	0.24	0.12	0.12	0.12
Δp [psi]	0.073	0.058	0.058	0.044	0.058	0.044	0.029	0.029	0.029	0.029	0.015	0.015	0.015	0.015	0.006	0.004
	<i>II/794[CFM]/48dB(A)*</i>															
P_g [MBH]	51	47	43	39	42	38	34	30	33	29	24	16	18	15	13	11
T_{p1} [°F]	94	100	105	110	85	90	96	101	76	81	85	85	60	66	73	80
Q_w [CFM]	0.41	0.35	0.35	0.29	0.35	0.29	0.24	0.53	0.24	0.24	0.18	0.12	0.12	0.12	0.12	0.06
Δp [psi]	0.058	0.044	0.044	0.029	0.044	0.029	0.029	0.015	0.029	0.015	0.015	0.015	0.015	0.015	0.006	0.004
	<i>I/518[CFM]/44dB(A)*</i>															
P_g [MBH]	40	37	33	30	33	30	27	23	26	22	15	13	15	13	11	9
T_{p1} [°F]	101	106	111	116	91	96	100	104	79	83	83	89	64	70	76	83
Q_w [CFM]	0.29	0.29	0.24	0.24	0.24	0.24	0.24	0.18	0.18	0.18	0.12	0.12	0.12	0.12	0.12	0.06
Δp [psi]	0.029	0.029	0.029	0.015	0.029	0.015	0.015	0.015	0.015	0.015	0.000	0.015	0.006	0.004	0.003	

Parameters	WING W150															
	164/158				176/140				158/122				140/104			
T_w [°F]	41	50	59	68	41	50	59	68	41	50	59	68	41	50	59	68
	<i>III/1824[CFM]/61dB(A)*</i>															
P_g [MBH]	108	100	91	83	91	83	75	67	75	66	59	50	58	49	41	32
T_{p1} [°F]	93	99	104	110	85	90	96	102	77	82	88	93	69	74	79	84
Q_w [CFM]	0.82	0.76	0.70	0.64	0.70	0.64	0.59	0.53	0.59	0.53	0.47	0.41	0.41	0.35	0.29	0.23
Δp [psi]	0.304	0.261	0.232	0.188	0.232	0.203	0.174	0.130	0.174	0.145	0.116	0.087	0.116	0.087	0.058	0.043
	<i>II/1206[CFM]/48dB(A)*</i>															
P_g [MBH]	90	83	76	70	76	70	63	56	63	56	49	42	48	41	34	26
T_{p1} [°F]	98	104	109	114	89	95	100	105	81	86	91	96	71	76	81	85
Q_w [CFM]	0.70	0.64	0.59	0.53	0.59	0.53	0.47	0.41	0.47	0.41	0.35	0.29	0.35	0.29	0.23	0.17
Δp [psi]	0.217	0.188	0.174	0.145	0.174	0.145	0.116	0.101	0.130	0.101	0.087	0.058	0.087	0.058	0.043	0.029
	<i>I/835[CFM]/43dB(A)*</i>															
P_g [MBH]	73	68	62	57	62	57	51	46	51	45	40	34	39	33	27	16
T_{p1} [°F]	104	110	115	120	95	100	105	110	85	90	95	99	75	79	83	83
Q_w [CFM]	0.60	0.53	0.47	0.41	0.47	0.41	0.41	0.35	0.41	0.35	0.29	0.23	0.29	0.23	0.23	0.12
Δp [psi]	0.159	0.130	0.116	0.101	0.116	0.101	0.087	0.072	0.087	0.072	0.058	0.043	0.058	0.043	0.029	0.014

Parameters	WING W200															
	164/158				176/140				158/122				140/104			
T_w [°F]	41	50	59	68	41	50	59	68	41	50	59	68	41	50	59	68
	<i>III/2589[CFM]/62dB(A)*</i>															
P_g [MBH]	160	145	134	122	134	122	111	100	111	99	88	76	87	76	64	52
T_{p1} [°F]	94	100	106	111	86	92	98	103	78	84	90	95	70	76	81	86
Q_w [CFM]	1.17	1.12	1.00	0.94	1.00	0.94	0.82	0.76	0.82	0.76	0.64	0.59	0.64	0.59	0.47	0.41
Δp [psi]	0.812	0.710	0.609	0.522	0.623	0.536	0.449	0.377	0.464	0.377	0.304	0.246	0.319	0.246	0.188	0.130
	<i>II/1854[CFM]/48dB(A)*</i>															
P_g [MBH]	139	129	118	108	119	108	98	88	98	88	78	68	77	67	57	46
T_{p1} [°F]	97	103	109	114	89	95	100	106	81	86	92	97	72	78	83	88
Q_w [CFM]	1.06	1.00	0.88	0.82	0.88	0.82	0.76	0.64	0.76	0.64	0.59	0.53	0.59	0.53	0.41	0.35
Δp [psi]	0.652	0.565	0.493	0.420	0.507	0.435	0.362	0.304	0.377	0.304	0.246	0.203	0.261	0.203	0.145	0.101
	<i>I/1206[CFM]/45dB(A)*</i>															
P_g [MBH]	116	107	98	90	99	90	82	73	82	73	65	56	64	56	47	38
T_{p1} [°F]	103	109	114	119	94	100	105	110	85	90	95	100	76	81	85	90
Q_w [CFM]	0.88	0.82	0.76	0.70	0.76	0.70	0.64	0.59	0.64	0.59	0.47	0.41	0.47	0.41	0.35	0.29
Δp [psi]	0.464	0.406	0.348	0.304	0.362	0.319	0.261	0.217	0.275	0.232	0.174	0.145	0.188	0.145	0.101	0.072

WING W100-200
WING E100-200
WING C100-200

8.2. ELECTRIC AIR CURTAIN – WING E100-200

T_{p1} – temperature of air at the inlet to the device
T_{p2} – temperature of air at the outlet from the device
P_g – heating output of the device

Parameters	WING E100				WING E150				WING E200			
	41	50	59	68	41	50	59	68	41	50	59	68
T _{in} [°F]	41	50	59	68	41	50	59	68	41	50	59	68
	III/1088[CFM]/59dB(A)*				III/1854[CFM]/61dB(A)*				III/2648[CFM]/62dB(A)*			
P _g [kW]	2/4/6	2/4/6	2/4/6	2/4/6	4/8/12	4/8/12	4/8/12	4/8/12	6/9/15	6/9/15	6/9/15	6/9/15
T _{out} [°F]	46/51/59	55/60/68	64/69/77	73/78/86	48/53/59	57/62/68	66/71/77	75/80/86	48/50/57	57/59/66	66/68/75	75/77/84
	II/824[CFM]/48dB(A)*				II/1206[CFM]/48dB(A)*				II/1883[CFM]/48dB(A)*			
P _g [kW]	2/4/6	2/4/6	2/4/6	2/4/6	4/8/12	4/8/12	4/8/12	4/8/12	6/9/15	6/9/15	6/9/15	6/9/15
T _{in} [°F]	48/53/60	57/62/69	66/71/78	75/80/87	50/57/66	59/66/75	68/75/84	77/84/93	50/53/60	59/62/69	68/71/78	77/80/87
	I/541[CFM]/44dB(A)*				I/853[CFM]/43dB(A)*				I/1265[CFM]/45dB(A)*			
P _g [kW]	2/4/6	2/4/6	2/4/6	2/4/6	4/8/12	4/8/12	4/8/12	4/8/12	6/9/15	6/9/15	6/9/15	6/9/15
T _{in} [°F]	51/60/69	60/69/78	69/78/87	78/87/96	55/66/78	64/75/87	73/84/96	82/93/105	53/59/69	62/68/78	71/77/87	80/86/96

8.3. WING C100-200 – COLD AIR CURTAIN



Parameters	WING C100			WING C150			WING C200		
	III	II	I	III	II	I	III	II	I
Fan speed	III	II	I	III	II	I	III	II	I
Qp [CFM]	1147	882	618	1883	1324	882	2707	2001	1377
noise level [dB(A)]*	62	49	45	63	49	43	63	49	45

*The noise level has been measured within a 10 ft distance from the device; reference conditions: semi-open space – wall-mounted device.

Parameters	unit of measure	WING W100-200			WING E100-200			WING C100-200		
		W100	W150	W200	W100	W150	W200	W100	W150	2m
Maximum width of a single door for one device	in	39	59	79	39	59	79	39	59	79
Maximum height of door	ft	12						13		
Heating output range	MBH	13 – 58	34 – 109	58 – 160	7/20 or 14/20	13/41 or 27/41	20/51 or 30/51	-		
Maximum flow rate	CFM	1089	1824	2589	1088	1854	2648	1147	1883	2707
Maximum temperature of heating medium	°F	203			-			-		
Maximum working pressure	psi	232			-			-		
Water volume	in ³	97	158	219	-			-		
Diameter of stub pipe connectors	"	3/4			-			-		
Supply voltage	V/ph/Hz	~115/1/60			~240/1/60 or ~240/3/60 or ~480/3/60	~240/3/60 or ~480/3/60		~115/1/60		
Power of the electric heater	kW	-			2 and 4	4 and 8	6 and 9	-		
Rated current of the electric heater	A	-			9/18/26 or 5/10/15 or 3/5/8	10/20/30 or 5/10/15	15/22/37 or 8/11/18	-	-	-
EC Engine power	HP	1/5	1/4	1/3	1/5	1/4	1/3	1/5	1/4	1/3
EC engine rated current	A	1.1	1.3	1.9	1.1	1.3	1.9	1.1	1.3	1.9
Weight	lbs	47	64	83	49	67	86	42	56	72
IP	-	44								

9. ELECTRICAL DIAGRAMS

9.1. Electrical diagram of WING W100-200-EC - 115V

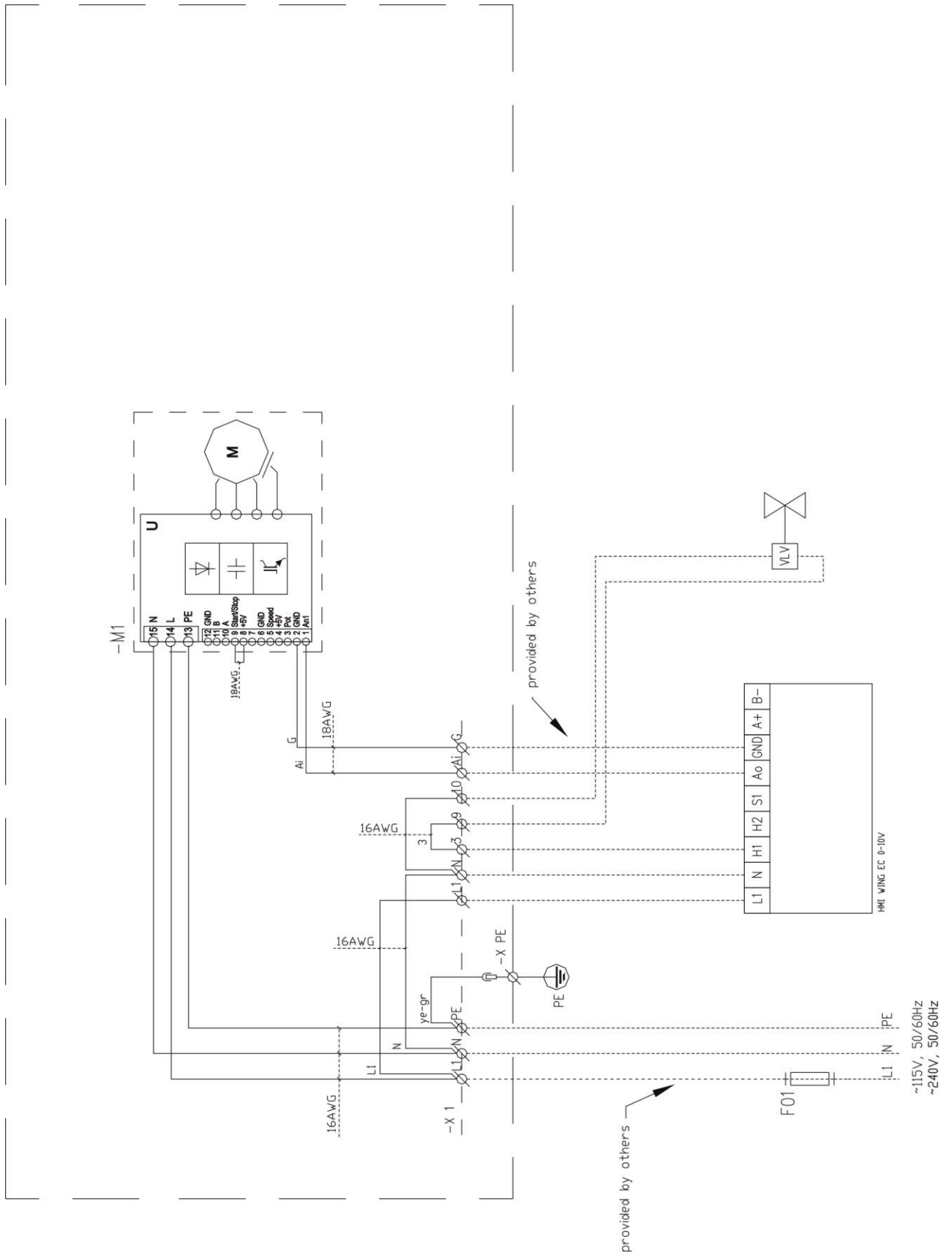

9.2. Electrical diagram of WING C100-200-EC - 115V

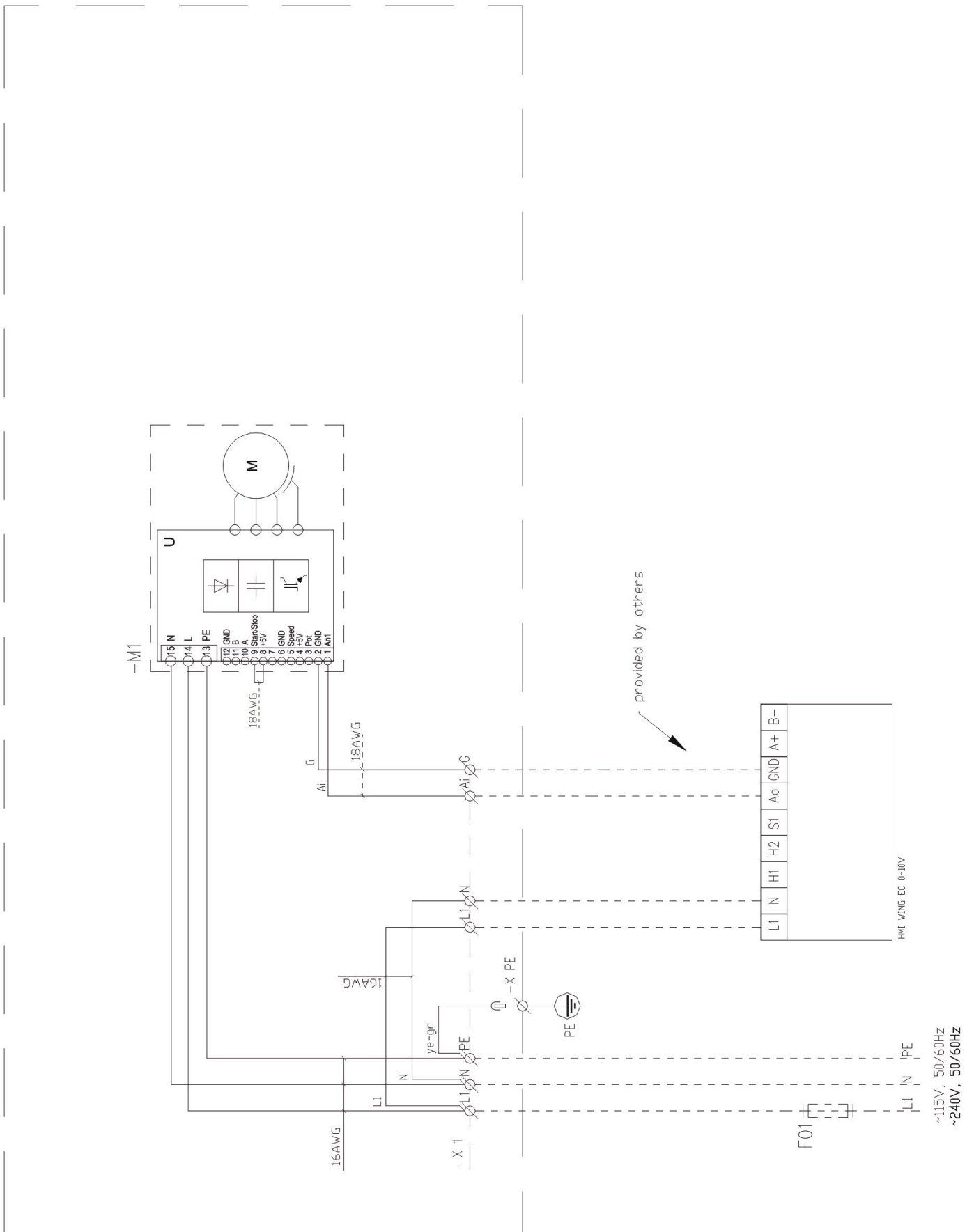

9.3. Electrical diagram of WING E100-EC – 1~240V

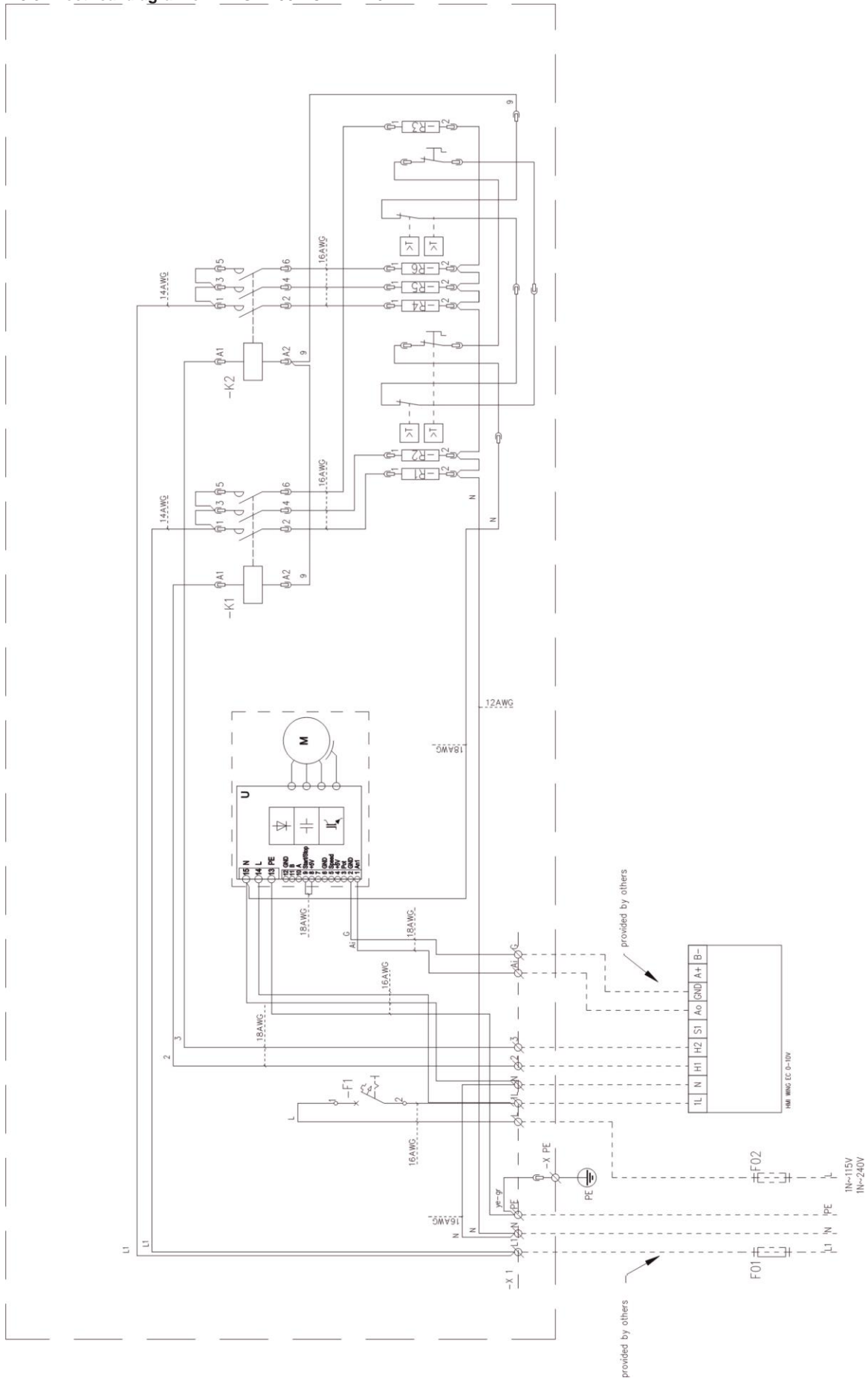

9.4. Electrical diagram of WING E150-200-EC -3~240V

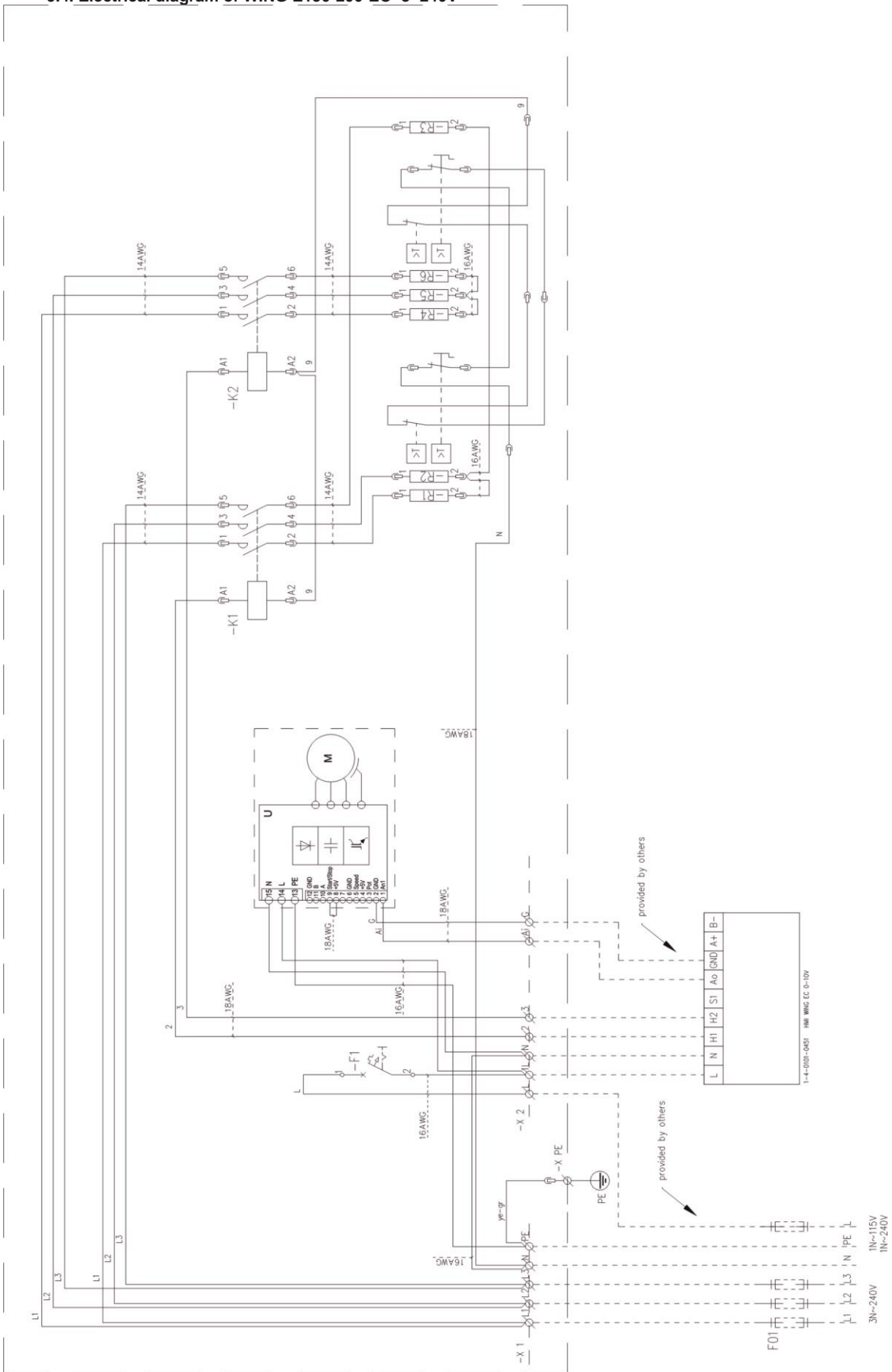

9.5. Electrical diagram of WING E100-EC- 3~230V and WING E100-200-EC – 3~480V

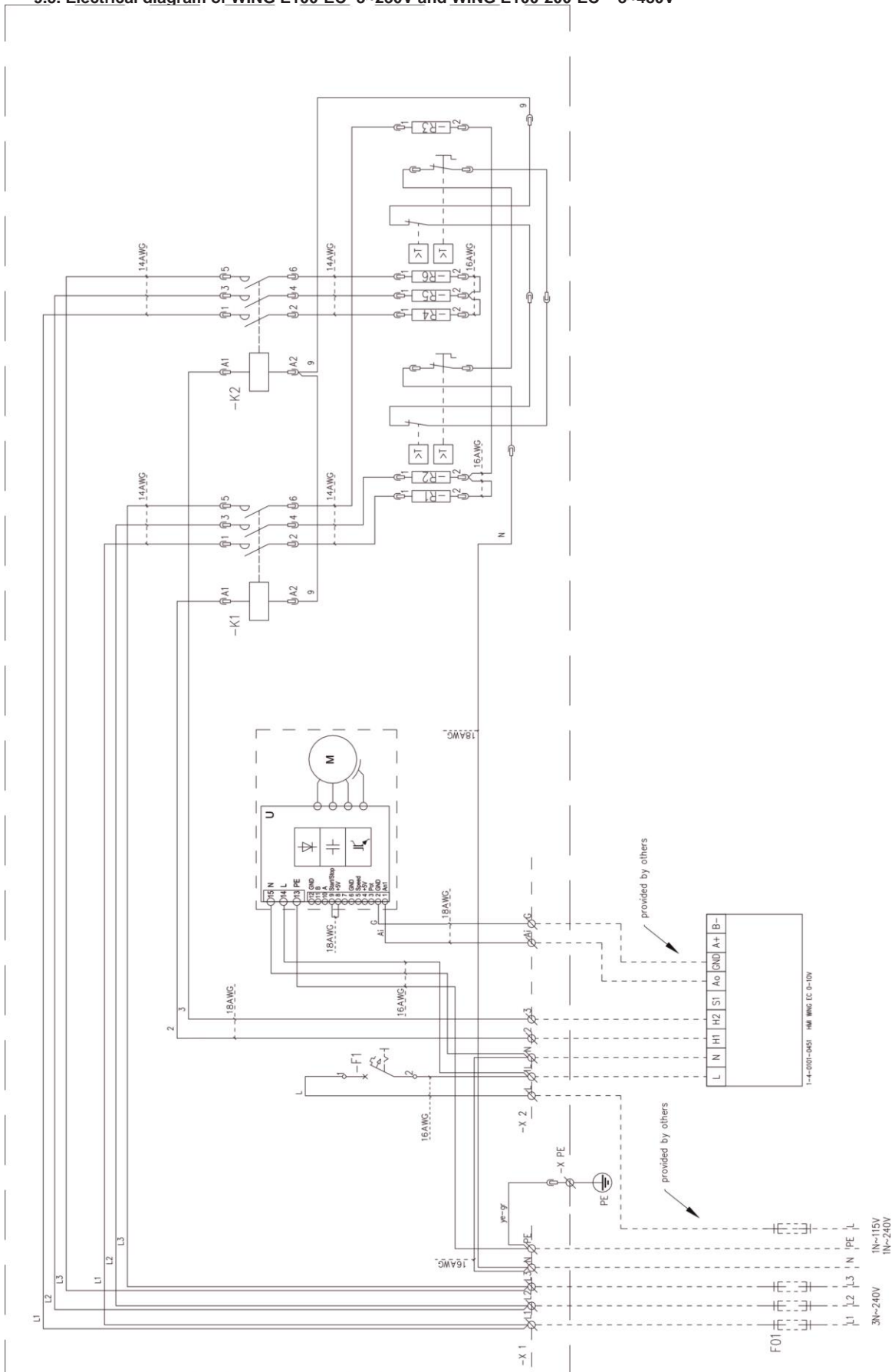

WING W100-200
WING E100-200
WING C100-200

Complaint Form

VTS POLSKA Sp. z o.o. Al. Grunwaldzka 472 A 80-309 Gdańsk Polska www.vtsgroup.com						
---	--	--	--	--	--	--

The company submitting the notification:
The company that installed the equipment:
Date of notification:
Type of device:
Factory number*:
Date of purchase:
Date of installation:
Place of installation:
Detailed description of defect:
Contact person:
Name and surname:
Telephone:
E-mail:

* This field must be filled, if the complaint notification refers to the following equipment: VOLCANO VR1 and VR2 unit, and WING air curtains.